

I CERTIFY THAT THIS PLAN, AS PREPARED, CONFORMS TO THE RULES AND REGULATIONS OF THE REGISTERS OF DEEDS OF THE COMMONWEALTH OF MASSACHUSETTS.



*Jason G. Racette*  
 NAME

4/23/2026  
 DATE

NOTES:

1. VERTICAL DATUM SHOWN IS MEAN LOW WATER DATUM (STATION: 8447636)
2. CONVERSION OF NAVD88 DATUM TO MEAN LOW WATER DATUM IS BASED ON DATA PROVIDED BY THE NOAA ONLINE VERTICAL DATUM TRANSFORMATION PROGRAM.
3. THE SUBJECT PROPERTY IS SHOWN ON THE TOWN OF FAIRHAVEN ASSESSORS' MAP 13, LOT 48.

ABUTTERS:

- (A) N/F CHRISTINE C. LAZAR  
 MAP 13, LOT 50  
 7 LAFAYETTE STREET
- (B) N/F LARS V. & RUTH E. OLSON  
 MAP 13, LOT 24  
 2 WEST STREET

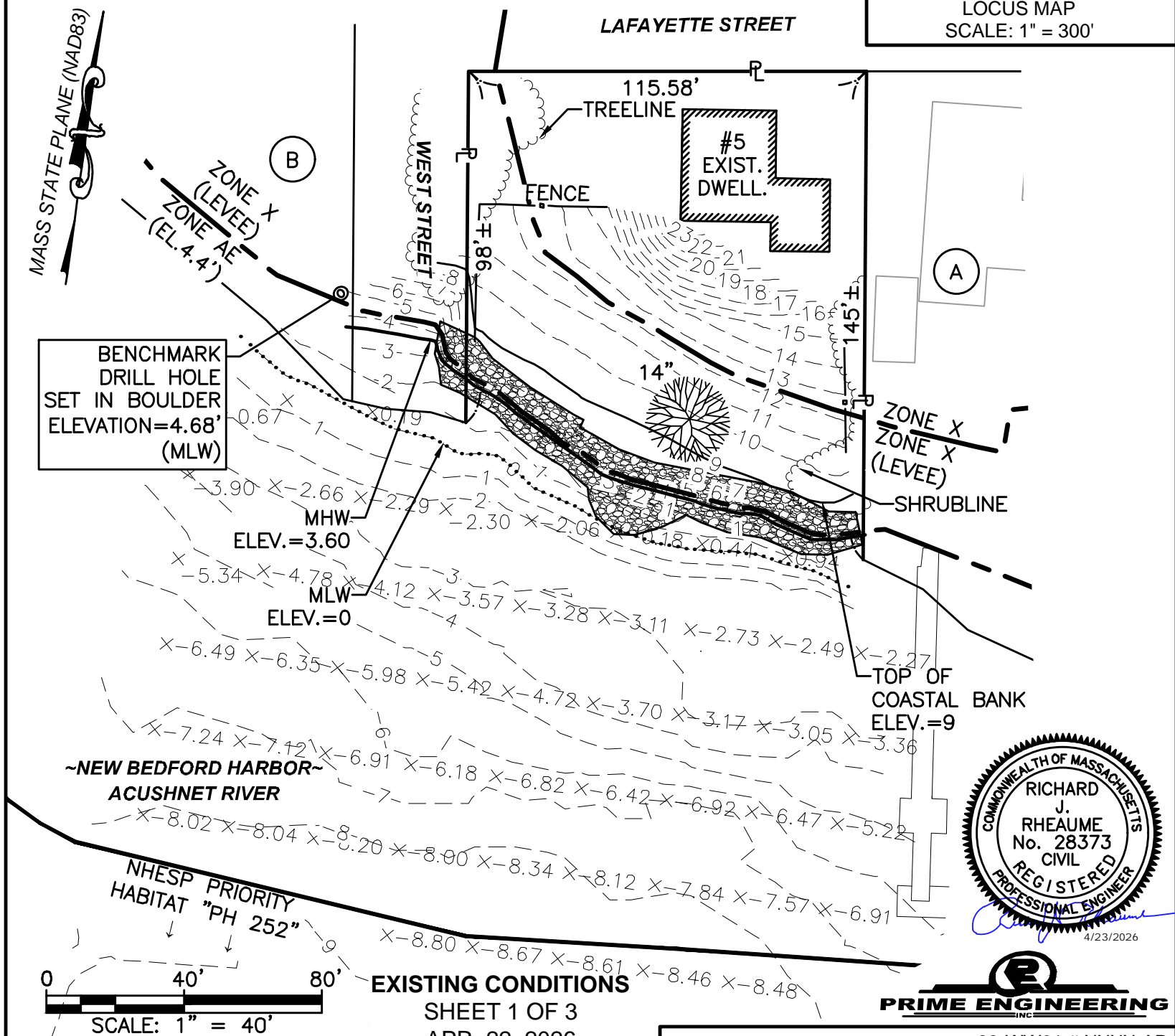
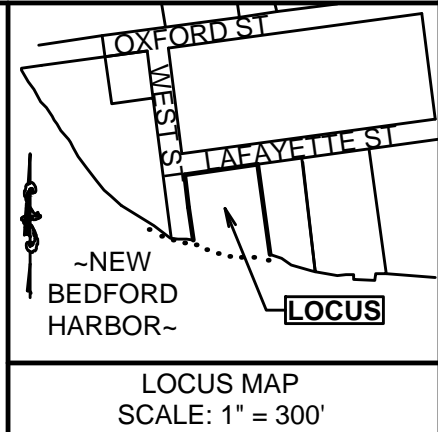

SHEET 1 OF 3  
 APR. 22, 2026

23-WW01 # XXXX-AP

PLAN ACCOMPANYING PETITION OF ALBERT SANTOS TO DREDGE, FILL, CONSTRUCT, ETC. AND MAINTAIN A DOCK WITHIN FILLED AND/OR FLOWED WATERS OF NEW BEDFORD HARBOR AT 5 LAFAYETTE ST, FAIRHAVEN, BRISTOL COUNTY, MASSACHUSETTS

I CERTIFY THAT THIS PLAN, AS PREPARED, CONFORMS TO THE RULES AND REGULATIONS OF THE REGISTERS OF DEEDS OF THE COMMONWEALTH OF MASSACHUSETTS.



*Jason G. Racette*  
NAME

4/23/2026  
DATE

NOTES:

1. VERTICAL DATUM SHOWN IS MEAN LOW WATER DATUM (STATION: 8447636)
2. CONVERSION OF NAVD88 DATUM TO MEAN LOW WATER DATUM IS BASED ON DATA PROVIDED BY THE NOAA ONLINE VERTICAL DATUM TRANSFORMATION PROGRAM.
3. THE SUBJECT PROPERTY IS SHOWN ON THE TOWN OF FAIRHAVEN ASSESSORS' MAP 13, LOT 48.

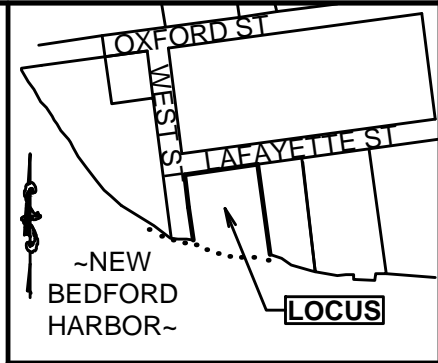

LOCUS MAP  
SCALE: 1" = 300'

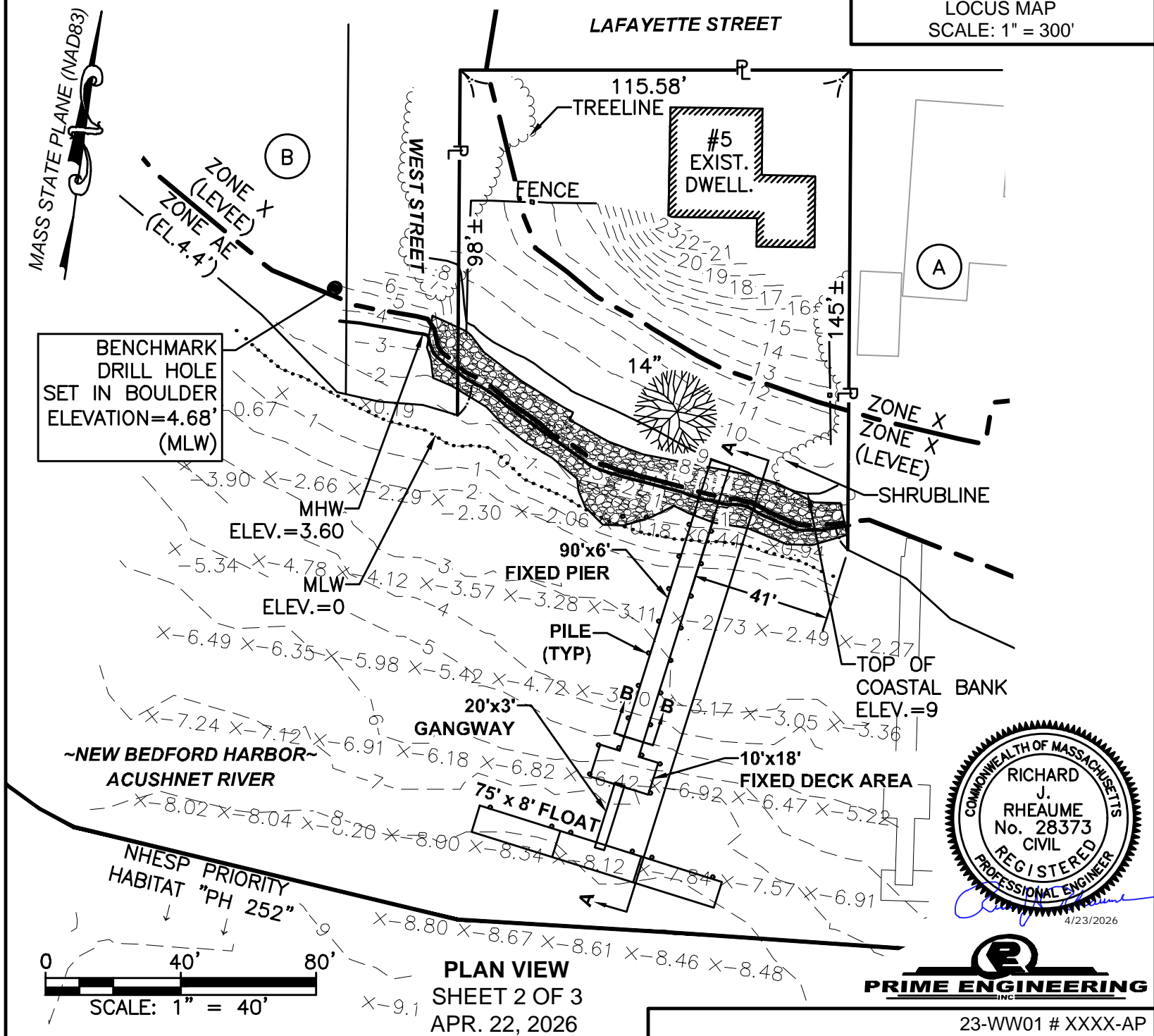

PLAN ACCOMPANYING PETITION OF ALBERT SANTOS TO DREDGE, FILL, CONSTRUCT, ETC. AND MAINTAIN A DOCK WITHIN FILLED AND/OR FLOWED WATERS OF NEW BEDFORD HARBOR AT 5 LAFAYETTE ST, FAIRHAVEN, BRISTOL COUNTY, MASSACHUSETTS

23-WW01 # XXXX-AP

I CERTIFY THAT THIS PLAN, AS PREPARED, CONFORMS TO THE RULES AND REGULATIONS OF THE REGISTERS OF DEEDS OF THE COMMONWEALTH OF MASSACHUSETTS.



*Jason G. Racette*  
NAME

4/23/2026  
DATE

**TIDE ELEVATIONS**

3.60	MEAN HIGH WATER	
1.62	MEAN SEA LEVEL	1.98'
0.00	MEAN LOW WATER	1.62'

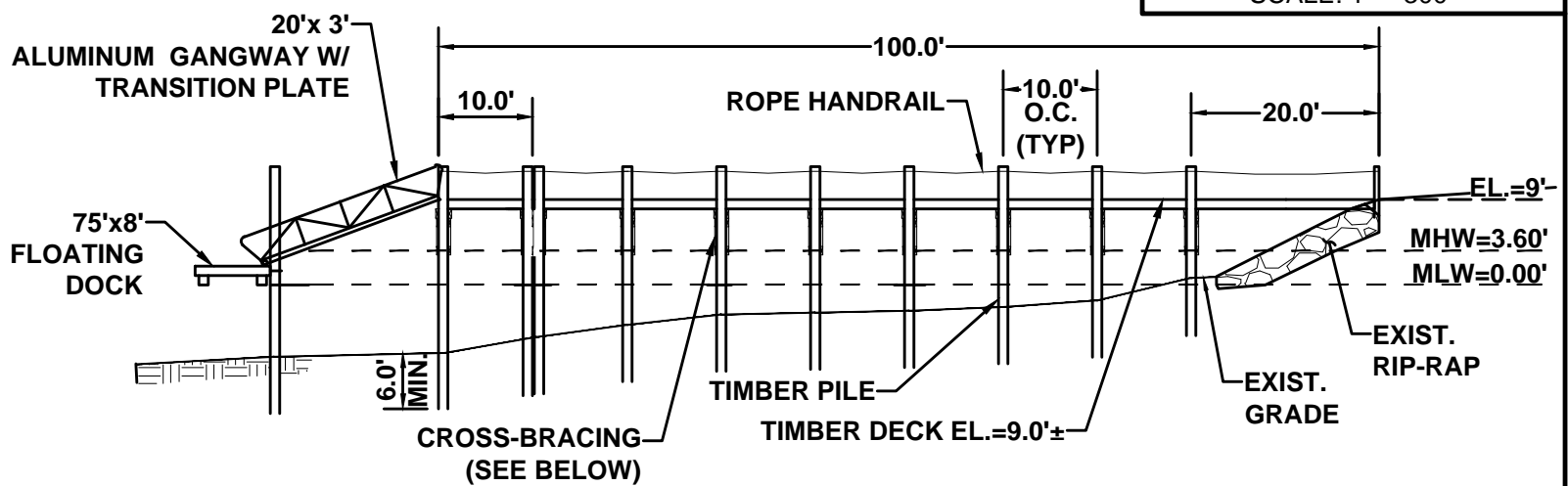
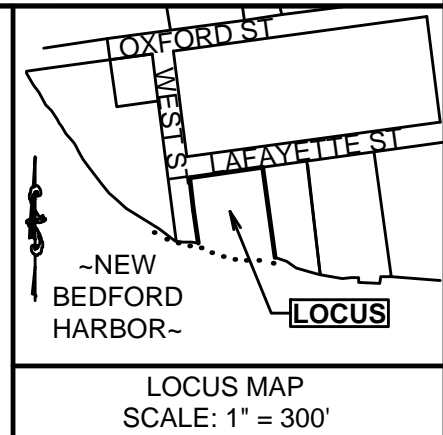

**PROFILE A-A**  
SCALE: 1"=20'

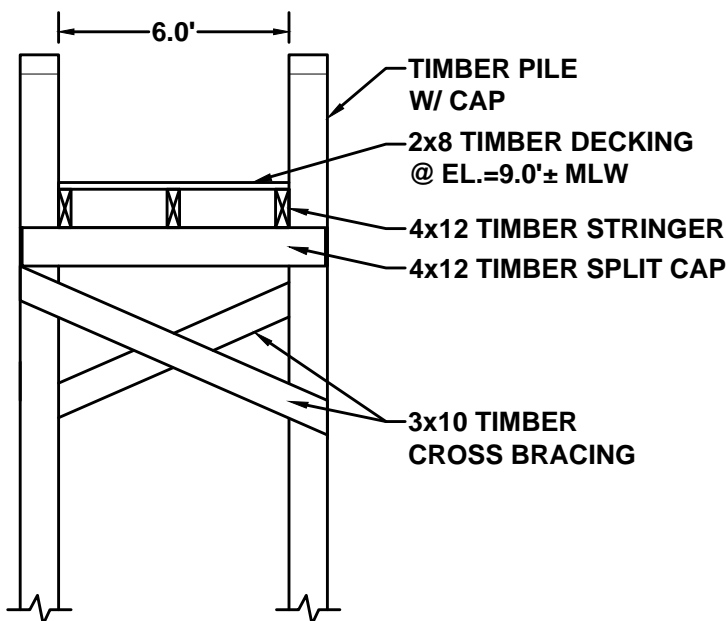

**PROFILE B-B**  
SCALE: 1"=5'

**WATER DISPLACEMENT VOLUME CALCULATIONS**

(26) 12" PILES (20.41 S.F. AREA)  
BETWEEN MLW AND MHW (3.60 FT)  
 $(.785 \text{ S.F.})(26 \text{ PILES})(3.60 \text{ FT}) = 73.48 \text{ CF}$   
2.72 CY WATER DISPLACEMENT VOLUME



**PROFILE & DETAILS**  
SHEET 3 OF 3  
APR. 22, 2026



23-WW01 # XXXX-AP

PLAN ACCOMPANYING PETITION OF ALBERT SANTOS TO DREDGE, FILL, CONSTRUCT, ETC. AND MAINTAIN A DOCK WITHIN FILLED AND/OR FLOWED WATERS OF NEW BEDFORD HARBOR AT 5 LAFAYETTE ST, FAIRHAVEN, BRISTOL COUNTY, MASSACHUSETTS